

# Data sheet HS2.4S-53

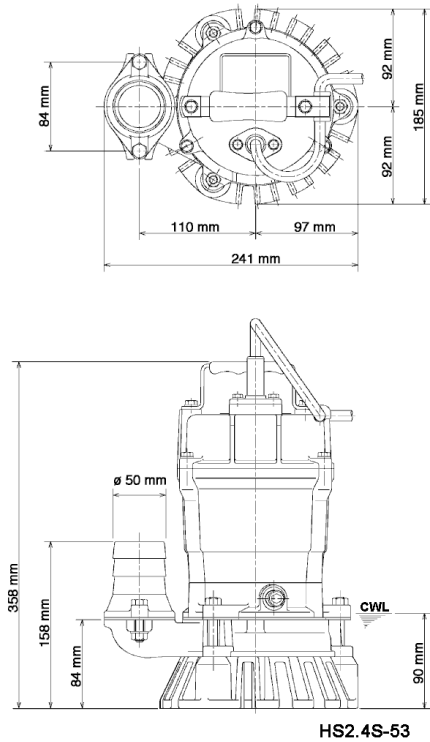

CWL: Continuous running water level

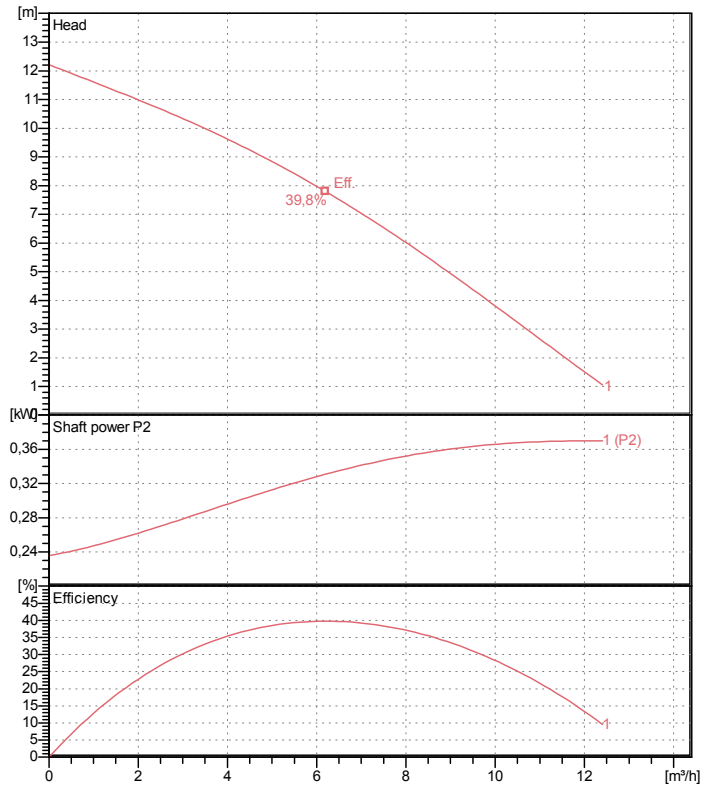

## Specification

Electric submersible pump  
 Degree of protection IP 68  
 Pressure resistance max. 10 m  
 Type of impeller semi-vortex  
 Max. solid handling 7 mm  
 Suitable for:  
 rain water, ground water, sand water

## Electric motor

Dry-type submersible induction motor  
 Insulation class E 2Poles 2723 1/min  
 Starting mode Directly  
 Rated voltage 230 V 50 Hz 1~  
 Power uptake 0,58 kW  
 Rated power 0,40 kW  
 Rated current 2,6 A  
 Start current 6,8 A

## Cable

H07RN-F 3Cx1mm<sup>2</sup>

## Motor Protection

Miniature protector in windings  
 (snap-action bi-metal device)

## Shaft seal

Double inside mechanical seal in oil bath  
 additional lubrication by oil lifting device

Primary seal

Silicon carbide on silicon carbide

Secondary seal

Carbon on ceramic

## Bearings

Shielded ball bearings, maintenance-free

## Materials

Impeller	Urethane rubber
Pump casing	FCD700 (EN-GJS-700-2)
Motor Frame	Aluminium die casting
Shaft	SUS403 (EN-X6Cr13)

## Discharge size

2" (50mm) BS-Coupling (threaded flange)

## Weight

11,3 kg (dry weight of the pump only without cable)

# Performance curve

## HS2.4S-53

Discharge port	2"
Head	12,2 m
Flow	12,4 m <sup>3</sup> /h
Rated power	0,40 kW
Power input	0,58 kW
Phases	1~
Voltages	230 V
Frequency	50 Hz
Rated current	2,6 A
Starting current	6,79 A
Number of poles	2
Speed	2723 1/min
Starting mode	Directly
Insulation class	E

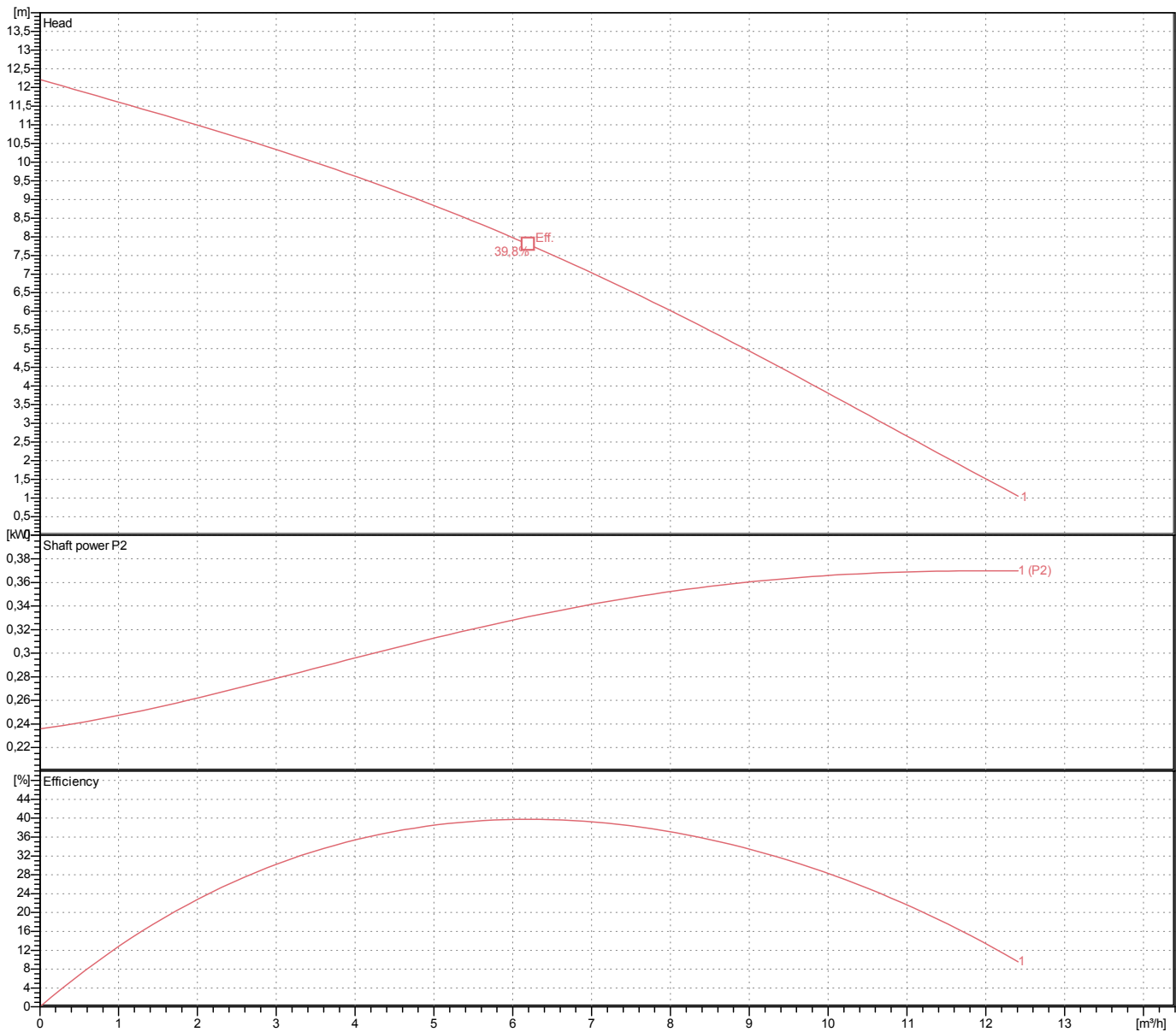

# Dimensions HS2.4S-53

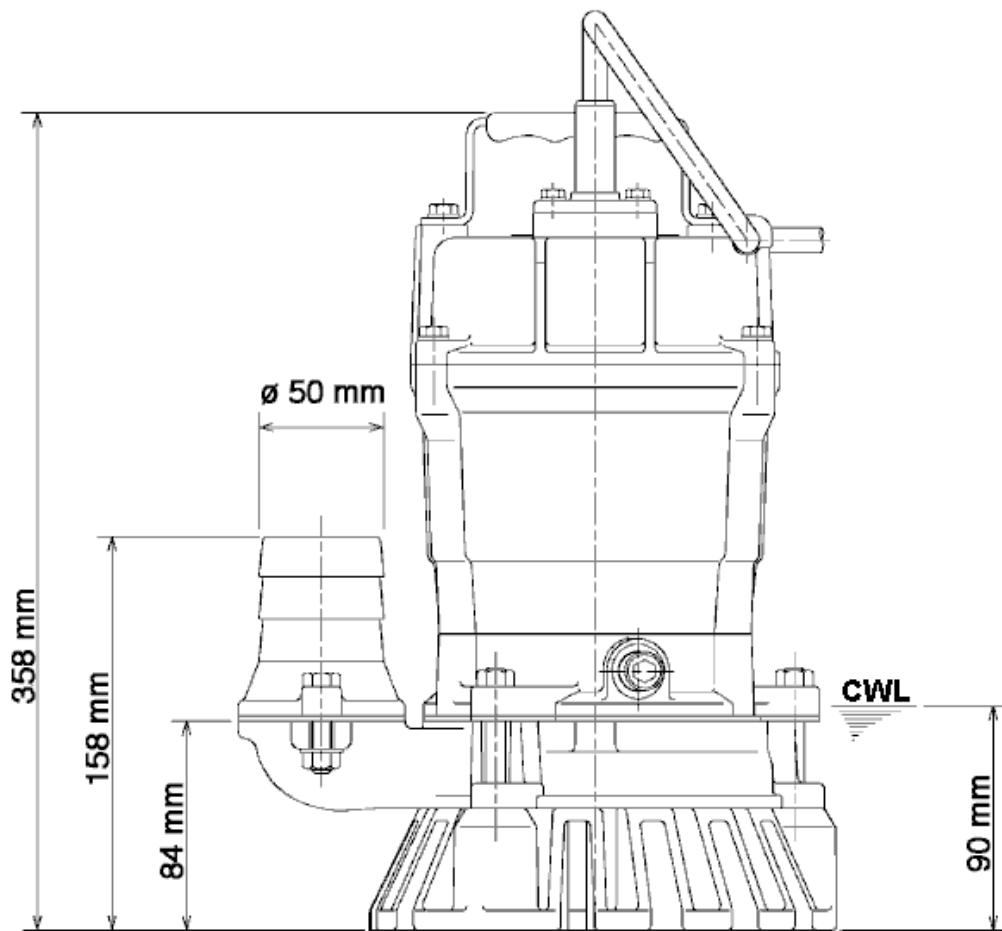
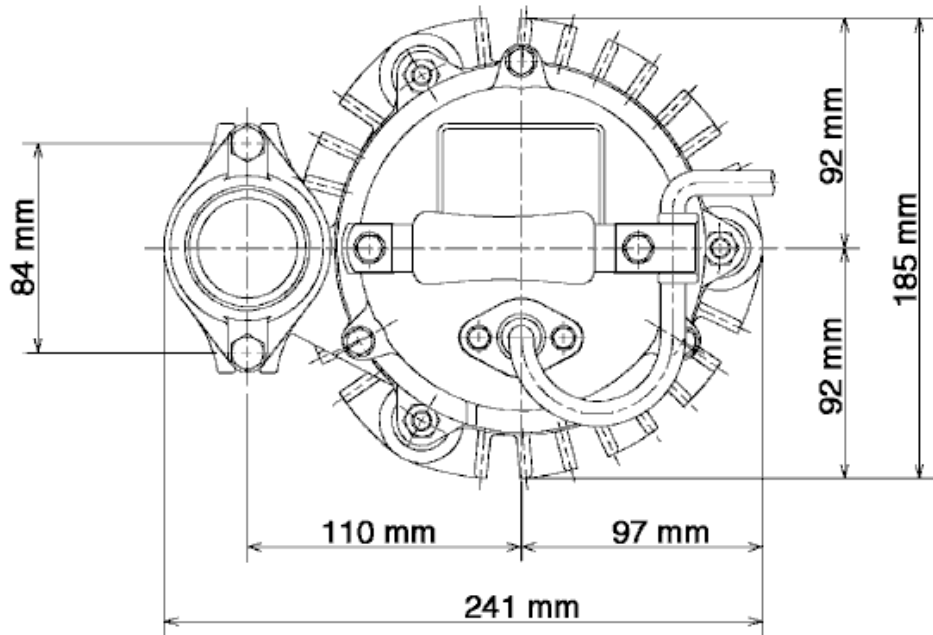

**HS2.4S-53**

CWL: Continuous running water level  
LWL: Lowest running water level

 **TSURUMI PUMP**

Tsurumi Europe GmbH  
12.10.2017 V.19 / 1.10.2016

Wahlerstr. 10 \* 40472 Düsseldorf \* Germany  
Tel.: +49-211-4179373 sales@tsurumi.eu  
Fax: +49-211-417937-480 www.tsurumi.eu

# Sectional drawing HS2.4S-53

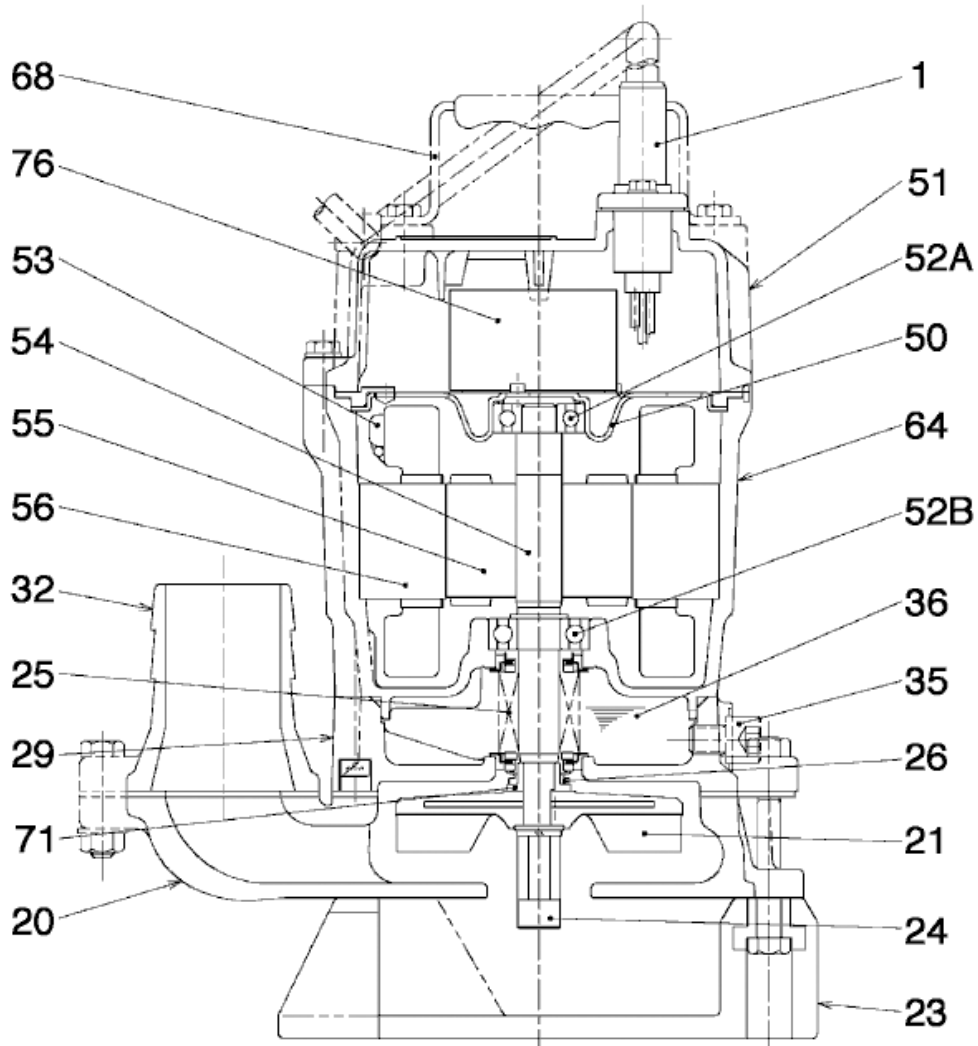

**HS2.4S-53**

No.	Description	Remark	No.	Description	Remark
1	Cable	H07RN-F3Cx1mm=x10m	54	Shaft	SUS403 (EN-X6Cr13)
20	Pump casing	FCD700 (EN-GJS-700-2)	55	Rotor	.
21	Impeller	Urethane rubber	56	Stator	.
23	Strainer	PVC	64	Motor Frame	Aluminium die casting
24	Agitator	Sintered alloy	68	Handle	Steel plate / natural rubber
25	Mechanical seal	W-14VL	71	Shaft protection sleeve	SUS304 (EN-X5CrNi18-10)
26	V-ring	Butadiene-acrylonitrile-rubber	76	Condenser	.
29	Oil casing	FC200 (EN-GJL-200)			
32	Discharge coupling	Aluminium die casting			
35	Oil screw	SUS304 (EN-X5CrNi18-10)			
36	Lubricant	Turbine oil (ISO VG32)			
50	Motor cover	Steel plate			
51	Main cover	Aluminium die casting			
52A	Upper bearing	6201ZZC3			
52B	Lower bearing	6202ZZC3			
53	Motor Protector 380/400/415V-50Hz KA314-HRXL00 (H.C)				